



www.regulus.eu



PG 500 Compact

Installation, Wiring and Operation Manual
PG 500 Compact Backup Power Supply

EN

PG 500 Compact

CONTENTS

1 ESSENTIAL INFORMATION	3
1.1 General decription	3
2 INSTALLATION, OPERATION	4
2.1 Description	4
2.2 Position of the unit	4
2.3 Recommended wiring	5
2.4 Commissioning	10
2.5 Turning on PG Compact with no grid power	10
2.6 Battery replacement	10
3 UNIT CONDITION INDICATION	11
4 POSSIBLE FAULTS, TROUBLESHOOTING	11
5 TECHNICAL DATA	12
6 MAINTENANCE	12

1 ESSENTIAL INFORMATION

This UPS of PG Compact series is intended preferably to power supply circulation pumps in heating systems.

THE APPLIANCE OPERATES WITH VOLTAGE DANGEROUS TO HUMAN LIFE. PLEASE STICK TO SAFETY INSTRUCTIONS GIVEN IN THIS GUIDE.

DO NOT DISMANTLE THE UPS COVER! THE COVER MAY BE DISMANTLED BY A QUALIFIED PERSON ONLY.

The load shall not exceed the inverter power output of 600 W.

The appliance is designed for indoor use.

It is not designed for outdoor operation, nor for operation in explosive environment.

Never charge very cold batteries (exposed to freezing temperatures).

The unit shall be placed in a sufficiently ventilated space. Ventilation openings shall not be covered and air intake shall not be obstructed.

Plug the power supply cable directly to a local wall socket. Do not use any extension cables.

1.1 General Description

When the unit is power-supplied from the grid, the electricity runs via its internal bypass directly to its outlet socket. At the same time, the battery is being charged. In case of a power failure, the inverter turns on and the load is fed from the integrated batteries. During charging, the temperature of the unit may rise to circa 45 °C (normal operation state).

NOTE! MORE APPLIANCES MAY BE CONNECTED BUT ONLY WITH RESPECT TO THE POWER OUTPUT OF THE PUMP. OF COURSE, WITH A HIGHER LOAD CONNECTED, THE BACKUP TIME GETS SHORTER.

The appliance connects to the power supply with a standard power cord with wall plug. The load is power supplied via the 230 V socket.

WARNING! WHEN TESTING A PUMP BACKUP, NEVER UNPLUG THE PG 500 COMPACT FROM ELECTRICAL SOCKET. DOING SO WOULD INTERRUPT THE PE LINE. DE-ENERGIZING SHALL BE DONE BY A CIRCUIT BREAKER OR A FUSE. MAKE SURE THE PUMP IS CONNECTED IN TN-S SYSTEM, i.e. three-wire system (L, N and PE).

When running from the battery, the LED marked "BACKUP" is lit. If the battery voltage falls to a low level, an acoustic alarm sounds prior to disconnecting.

WARNING – Whenever handling a battery, the unit shall be turned off and disconnected from the power supply.

Features of the UPS

Fast automatic line-to-battery switching

Built-in battery charger.

Intelligent charger control with battery overload and overcharge protection.

Protection against overload, battery overcharge and overheating.

LED indications and buzzer alarms.

The backup power supply may be disconnected from the mains only after the batteries are fully charged. A battery can be considered fully charged when there were no power cuts for two days. Storing a discharged battery will cause its definite destruction!

2 INSTALLATION, OPERATION

2.1 Description

Front panel



- 1 ON/OFF push button
- 2 Red - backup, battery operation
- 3 Orange - overload, the unit is overloaded
- 4 Green - normal, grid power is present

Rear panel



- 1 2 Backed up sockets = OUTPUT
- 3 Non backed up socket
- 4 Integrated power supply cable
- 5 Fuse

2.2 Position of the unit

Place the unit on a hard, dry surface in a well ventilated room, at a safe distance from direct heat sources. In order to secure sufficient cooling, leave at least 100 mm of free space around it. The unit is designed for indoor use only. Do not leave the unit in direct sunlight. Do not leave the unit in excessively hot environment. Do not expose the unit to excessive moisture. Do not leave the unit in a dusty place.

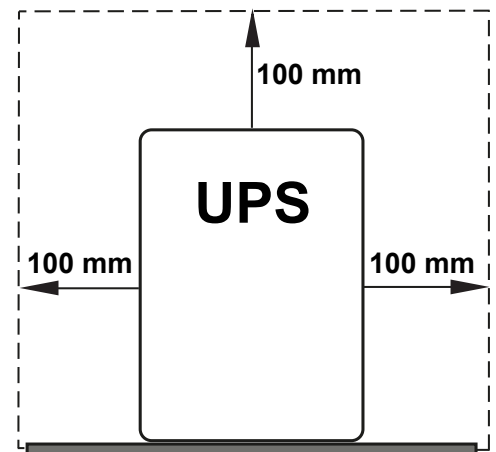
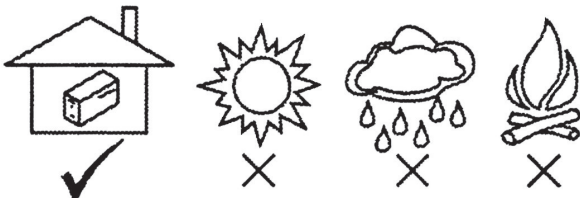

2.3 Recommended wiring

- it is recommended to use solely an installation contactor with a 230 VAC coil, 2x NO + 2x NC
- it must be ensured that the PE lead cannot be disconnected!
- unconditional separation of the circuit fed from PG 500 from the mains shall be respected

IR12 CTC controller

Backup of circulation pump of a heat pump.

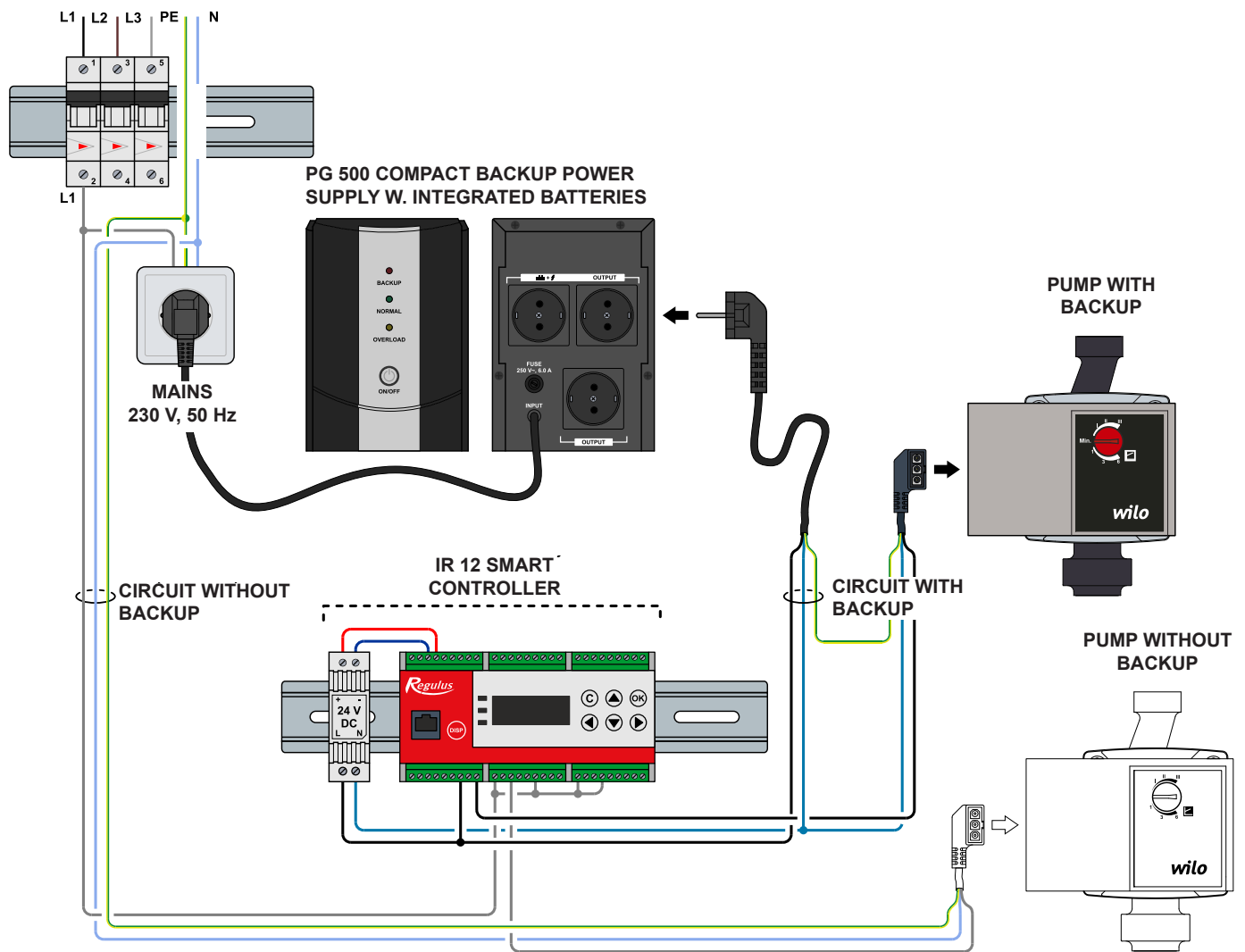

! Do respect the separation between the circuits with and without backup. Not only for the live wire but also for the neutral one!

DETAILED PIC. SHOWING TERMINAL BOARDS MARKING AND WIRING

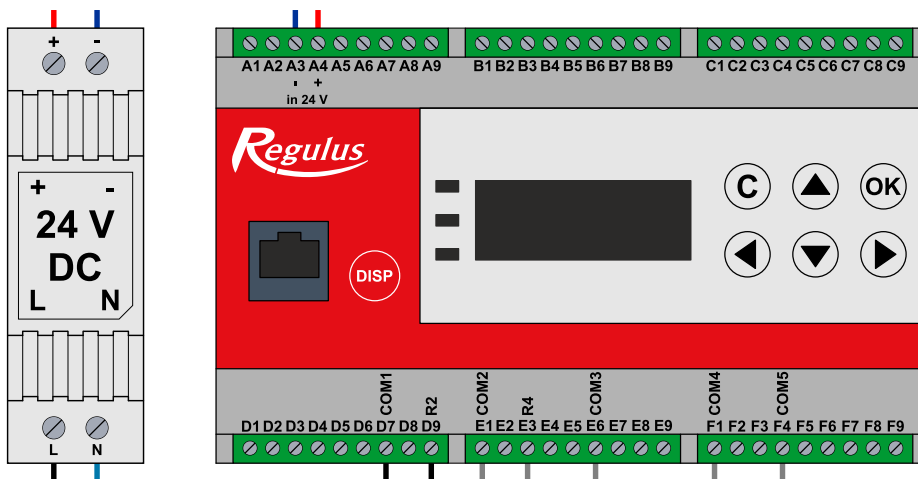

IR12 CTC controller + fireplace module

Backup of circulation pump of a fireplace.

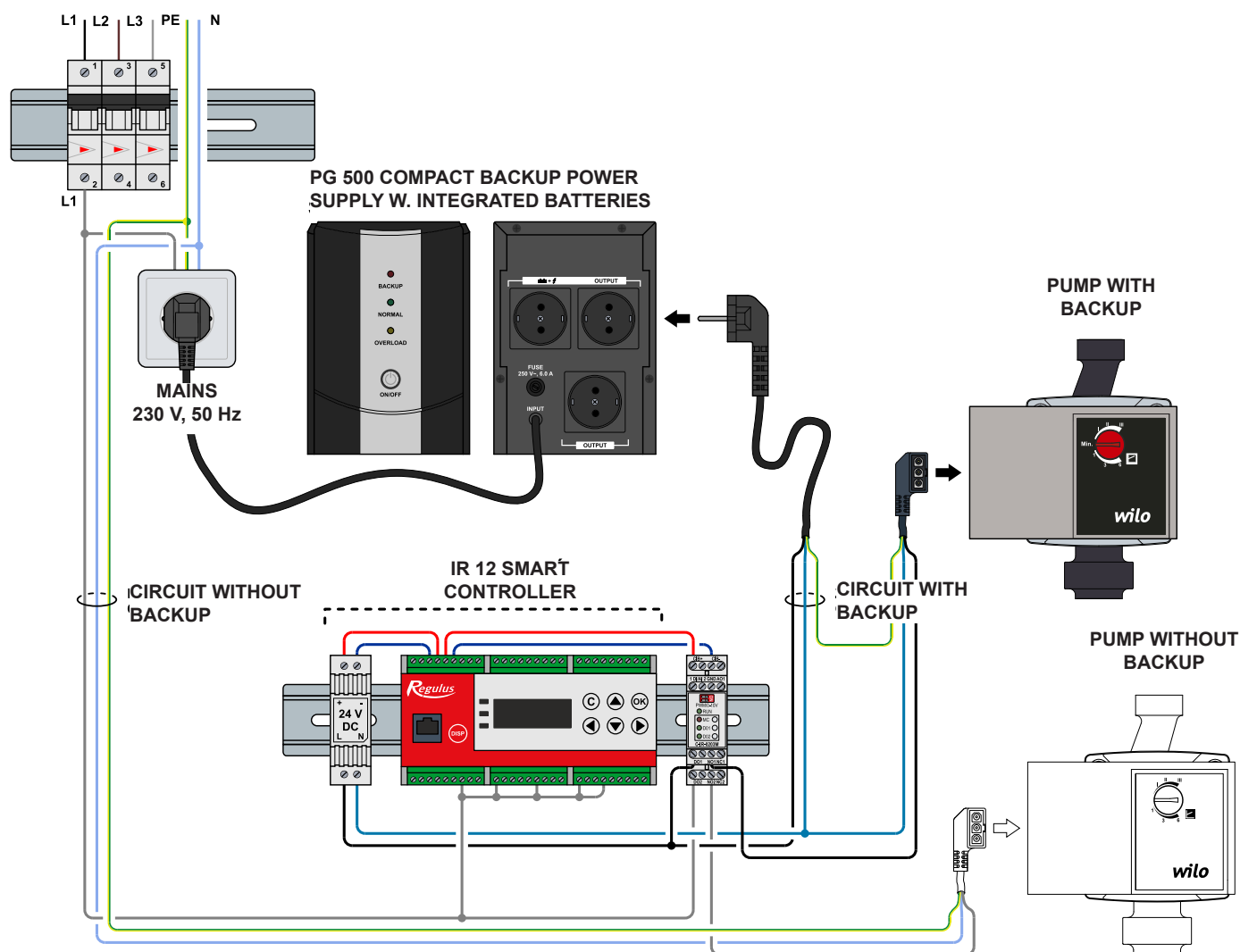

! Do respect the separation between the circuits with and without backup. Not only for the live wire but also for the neutral one!

DETAILED PIC. SHOWING TERMINAL BOARDS MARKING AND WIRING

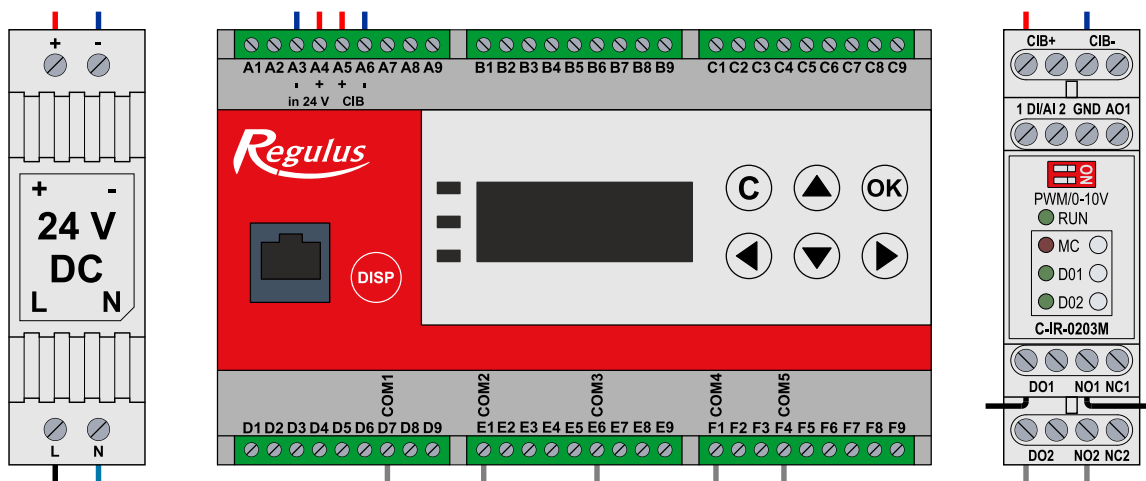

IR12 CTC controller + PWM module

Backup of a PWM-controlled solar pump.

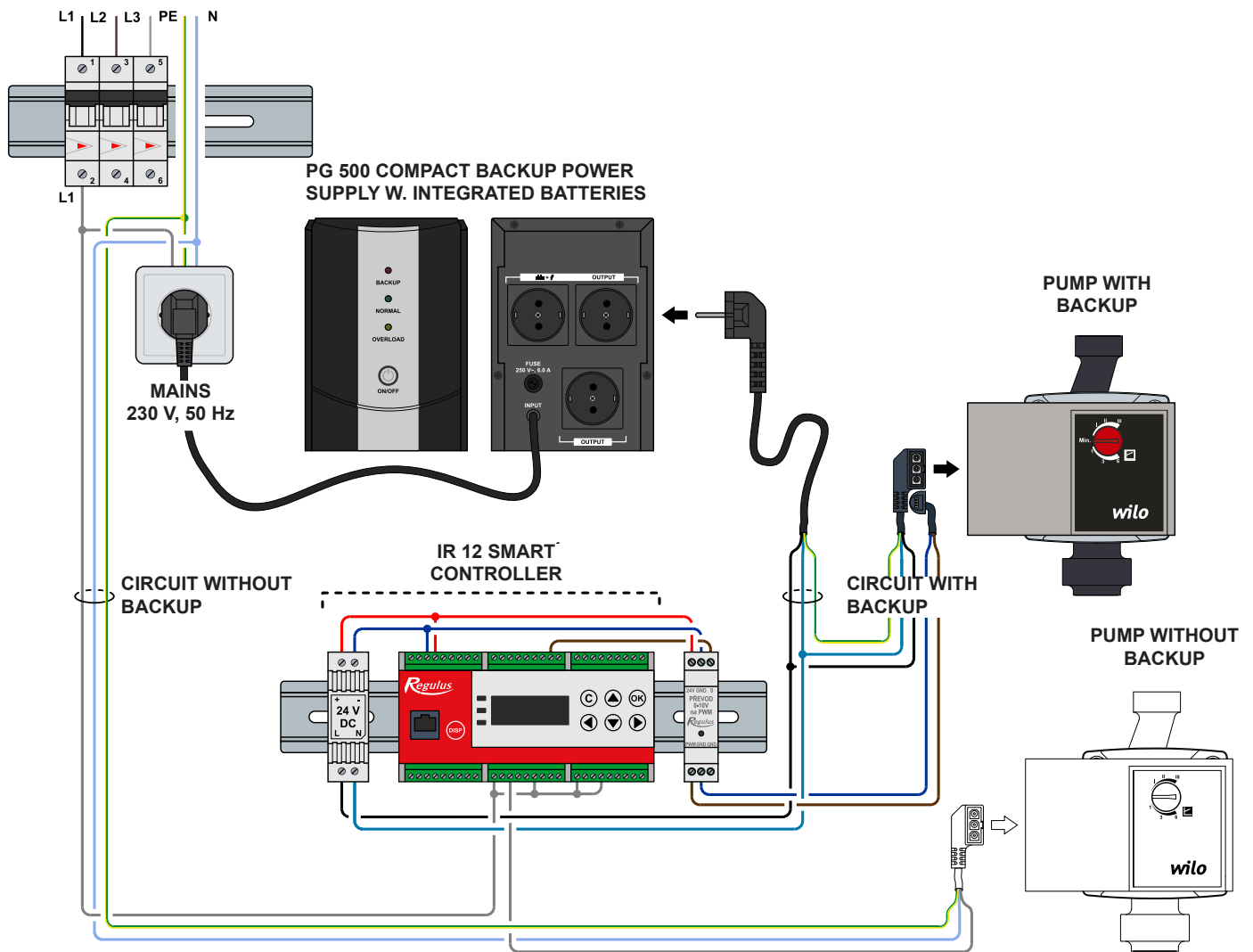

! Do respect the separation between the circuits with and without backup.
 !Not only for the live wire but also for the neutral one!

DETAILED PIC. ŠHÓWING TERMINÁL BOARDS MARKING AND WIRING

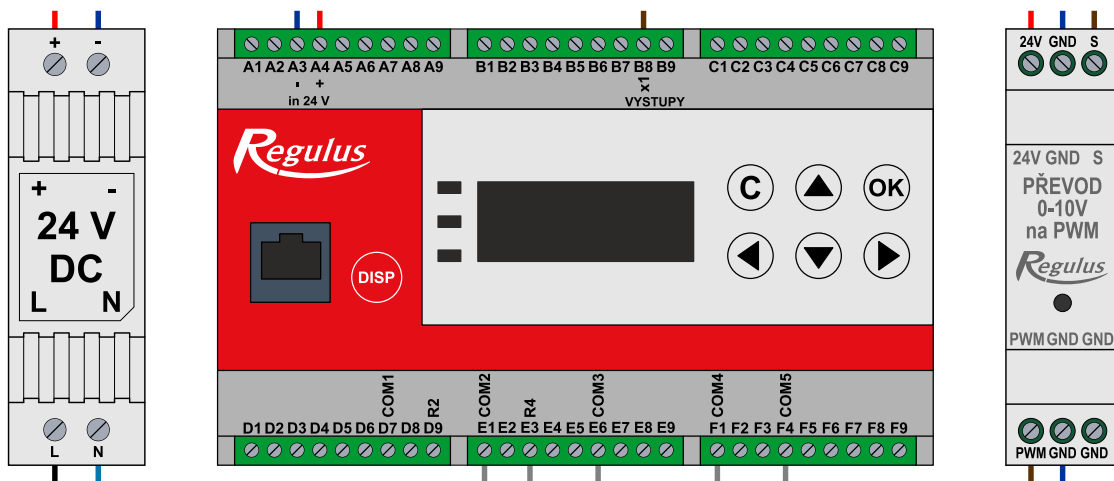

Fireplace

Backup of a fireplace circulation pump with flue thermostat.

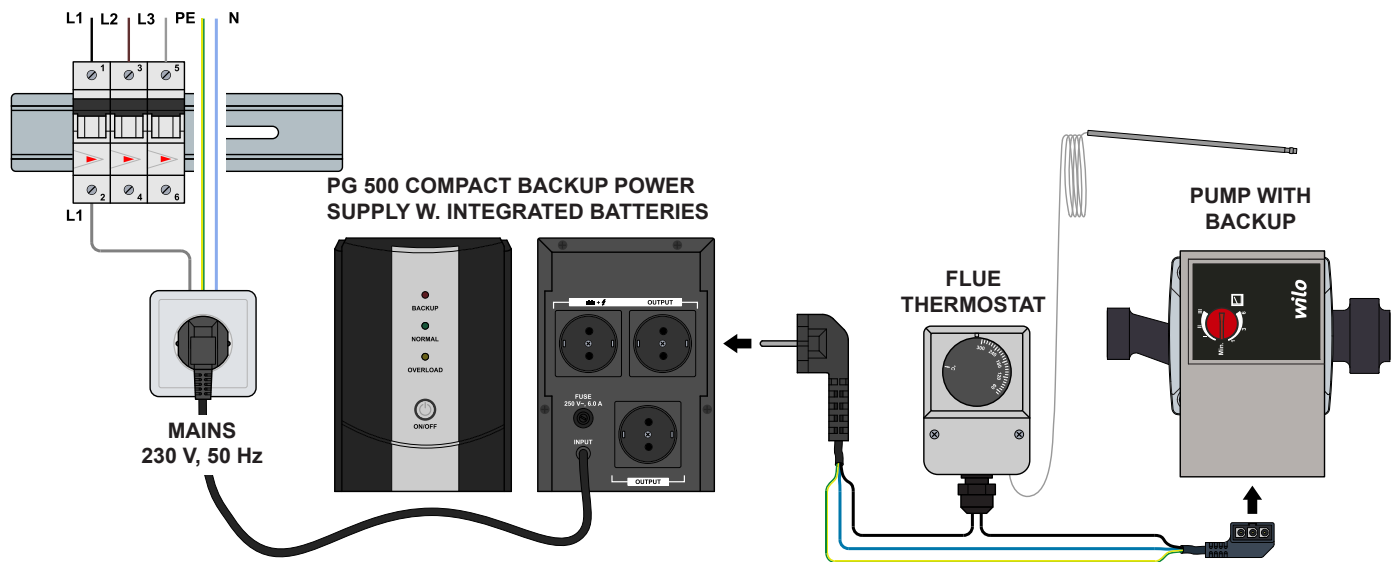

STDC, TRS etc. controller

Pump backup

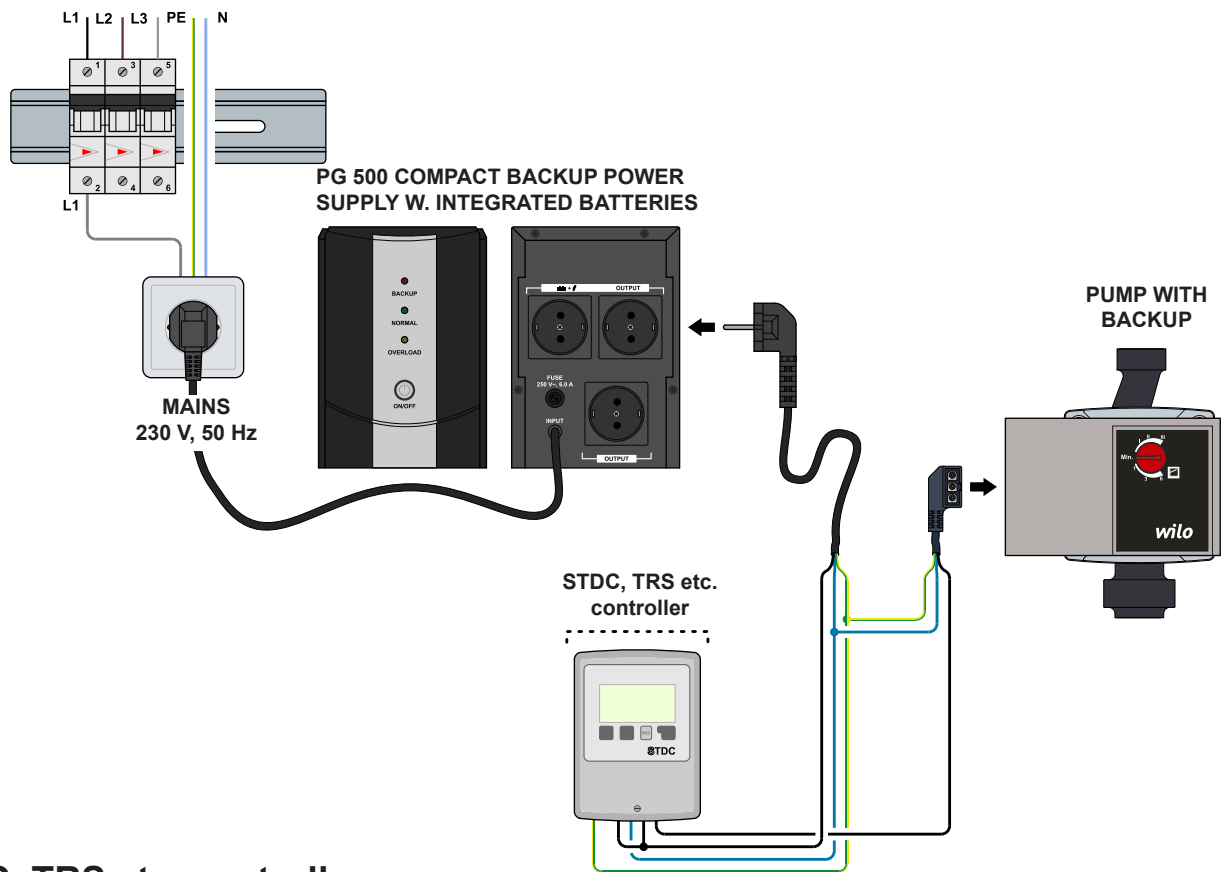

STDC, TRS etc. controller

Backup of a PWM-controlled pump.

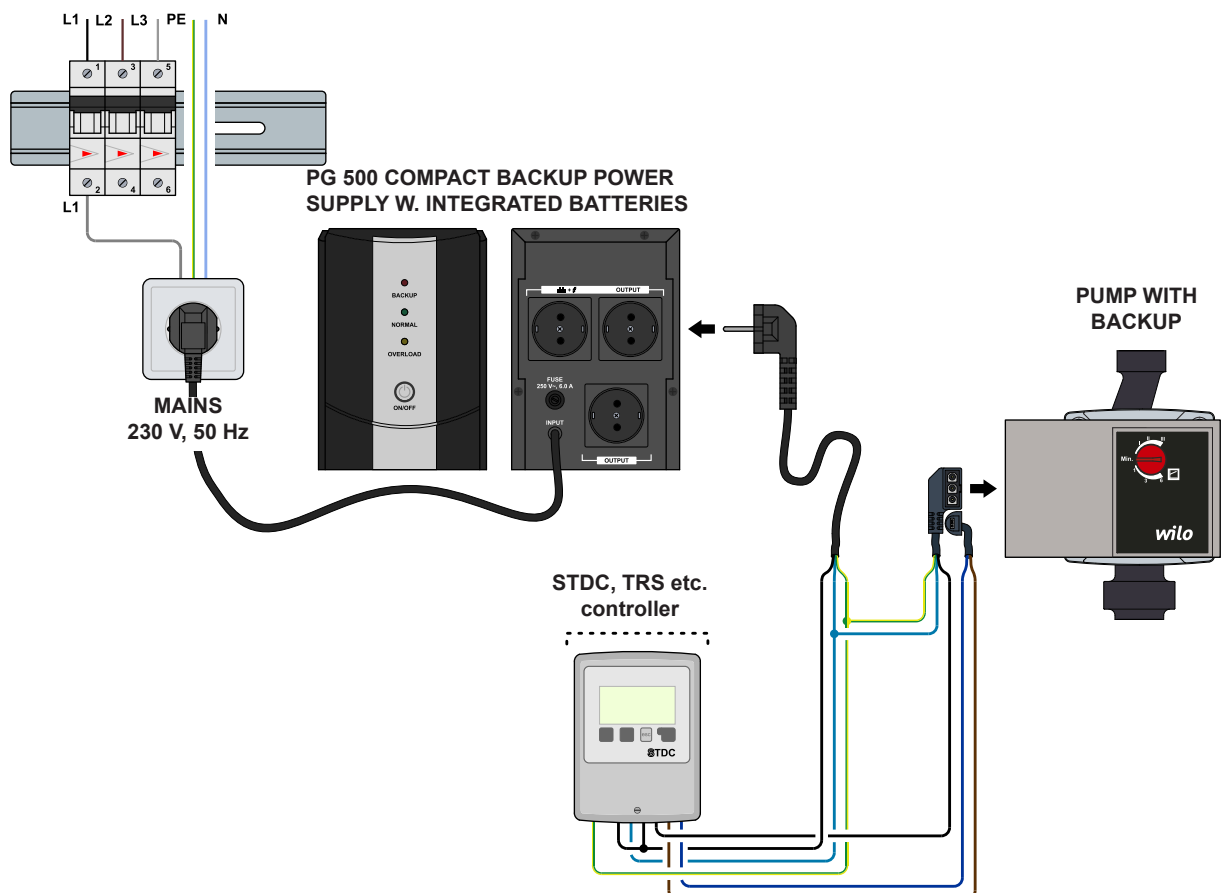

2.4 Commissioning

1. Make sure the power grid voltage corresponds to the voltage the UPS is designed for.
2. Plug the power supply cord into a wall socket. **WARNING** - from the moment on the batteries are being charged.
3. Connect your pump or another load by plugging its cable into the socket of PG 500 Compact. It is necessary to stick to a TN-S system (three-wire system, i.e. live wire is black, neutral wire is pale blue and protective earth wire is yellow-green). No terminal of the unit's outlet socket shall get connected to any lead of mains or any other electric wiring. The unit is designed for a closed circuit. If the unit's outlet got connected with the mains, there would be a danger of destroying the connected appliances, the unit itself, and even causing harm to health and property. The only lead that may be connected outside TN-S network is the protective yellow-green lead.
4. Press ON/OFF push button to turn the UPS on. A signal will sound and all the LEDs will flash once. The green LED will stay lit, indicating that the unit is running (standard mode, ready for backup).
5. Now you can turn on a pump or another load and test power grid operation without the inverter. The inverter will turn on automatically at a power supply failure.

Auto test on start

After the unit is switched on, all LED indicators will blink twice. The unit is then ready for operation.

Silent mode

During battery operation, short pressing the ON/OFF button will turn on/off the buzzer alarms.

The Weak battery alarm cannot be switched off.

Auto start

If batteries went discharged and the unit switched off, it will turn on as soon as the power supply is restored.

Overload

The unit will recognize overload and disconnect the outlet after a while in order to avoid its own destruction.

Auto switch off

Under low battery voltage, the unit will disconnect the load and switch itself off in order to protect the battery.

Turning off

By pressing and holding the ON/OFF button for 3 sec. the unit will be switched off.

2.5 Turning on PG Compact with no grid power

The UPS can be turned on without grid power, just from the battery.

Never disconnect 230 V power supply when the UPS is in operation, the earth protection of both PG 500 Compact and the connected load would get interrupted.

Verify that the total earth leakage current does not exceed 2.7 mA when all loads are connected (following the EN 62040-1 standard)..

2.6 Battery replacement

The unit is equipped with two integrated 12V batteries. They shall be replaced only with batteries of the same type. Replacement may be performed only by a qualified person. Before starting the replacement, take off your wrist watch, rings or other metal items. Use tools with insulated handles. Do not throw the batteries into a fire, do not open/damage them. The acid inside is toxic, dangerous to skin and eyes.

Batteries shall be disposed of as dangerous waste.

3 UNIT CONDITION INDICATION

Visual indication	Power grid operation - NORMAL green LED is lit
	Battery operation – BACKUP red LED is lit
	Overload – OVERLOAD orange LED is lit
Audio indication	Low battery voltage - signal every second
	Battery operation - signal every 8 sec.
	Defect / overload - uninterrupted tone

4 POSSIBLE FAULTS, TROUBLESHOOTING

Situation	Possible cause	Solution
The unit cannot be turned on	<ul style="list-style-type: none"> • The unit is disconnected from grid and overloaded • The inlet fuse is blown • Low voltage in power grid • The unit is defect 	<ul style="list-style-type: none"> • Connect to power grid and reduce the load. • Replace the fuse and reduce the load. Some of the connected devices may be short-circuited. • Check if the power grid voltage corresponds to the values required. • Contact service staff.
Red LED is lit and the signal sounds every 8 sec.	<ul style="list-style-type: none"> • The unit is powerless 	<ul style="list-style-type: none"> • Depending on the battery charge level and the connected load, the unit will supply energy.
Red LED is lit and the signal sounds every second	<ul style="list-style-type: none"> • Low battery voltage, the unit will disconnect soon 	<ul style="list-style-type: none"> • Connect grid power supply and let the batteries fully charge. Take appropriate measures on the connected system if necessary.
The backup time is significantly reduced.	<ul style="list-style-type: none"> • Overload • Batteries have not been fully charged • Charging circuit does not work • Battery lifetime overi 	<ul style="list-style-type: none"> • Disconnect excess load. • Leave the unit connected to power grid for at least 24 hours, preferably 48. • Contact service staff. • Contact service staff.

5 TECHNICAL DATA

PG Compact Backup Power Supply		
Model		PG 500 Compact
Input	Voltage/frequency	230 V
	Voltage/frequency	170 - 260 V / 50 Hz
	Fuse	250 V / 6 A
Output	Inverter power output	600 W
	Nominal voltage	230 V
	Voltage tolerance (backup mode)	195 - 255 V
	Frequency	50 Hz
	Frequency tolerance (backup mode)	± 1 Hz
	Waveform (backup mode)	modified sine-wave
Others	Dimensions (LxWxH)	335 x 125 x 195 mm
	Weight	11 kg incl. batteries
	Ambient working temperature	0 - 40 °C
	Ambient relative humidity	0 - 90 %, non condensing
	Noise level	quiet operation (no fan)

Battery		
Type		lead battery for UPS
Technical data	battery nominal voltage	12 V
	number	2
	battery capacity	18 Ah (2 x 9 Ah)
	max. discharge current	3 A

Backup period with recommended battery		
Model		PG500 Compact
Small load	output load power consump. (230 V)	20 W
	backup period	5 h
Higher load	output load power consump. (230 V)	45 W
	backup period	3 h 30 min

6 MAINTENANCE

PG 500 Compact does not require any special maintenance. Disconnect it from the mains before cleaning. If needed, wipe its surface with a wet cloth without detergent. Do not use a spray for cleaning. After cleaning re-connect the unit to the mains.

Cleaning inside the unit may be performed by a qualified person only.