

BOILER OUTPUT CONTROL

RT4 Thermostatic draft regulator

Thermostatic draft regulator for solid fuel boilers designed to control boiler output by opening or throttling a combustion air damper. The boiler output is modified in such a way that the working fluid temperature (heating water, antifreeze fluid, heat transfer oil) at the boiler outlet reaches the temperature set by the knob.

The regulator can be installed vertically or horizontally. Its working position (orientation) shall correspond to the picture “Working positions of RT4 regulator”.



TECHNICAL DATA

CONNECTION SIZE	G 3/4" M
NOMINAL PRESSURE	PN 6
MAX. WORKING PRESSURE	0.6 MPa
MAX. FLUID WORKING TEMPERATURE	120 °C
CONTROL RANGE OF FLUID TEMPERATURE	30 - 90 °C
MAX. AMBIENT TEMPERATURE	60 °C
CHAIN LOAD	100 - 1 000 g
WEIGHT	420 g
CODE	13878

DIMENSIONS

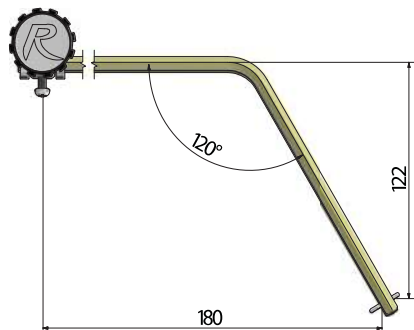
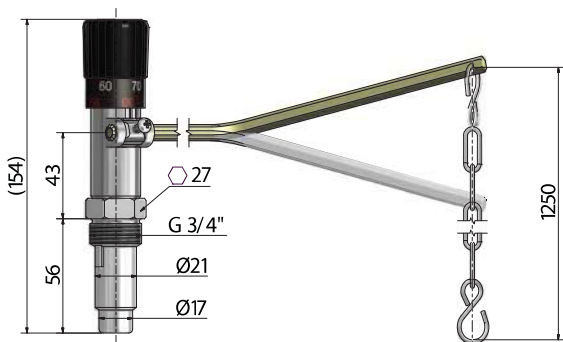

Advantages of RT4 draft regulator:
 High control power
 Resistance to dusty environment
 Its design permits disassembly
 Nickel plated sheath

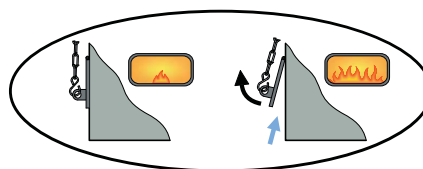
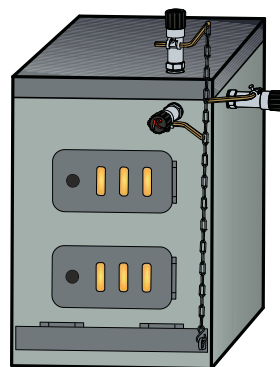

Working positions of RT4 regulator.

Thanks to the many versions and many working positions shown in the fig., the regulator can be easily mounted on any current boiler.